

FEATURES

- ▶ Fully Encapsulated Plastic Case for Chassis and DIN-Rail Mounting Version
- ▶ Ultra-wide 4:1 Input Voltage Range
- ▶ Fully Regulated Output Voltage
- ▶ Excellent Efficiency up to 92%
- ▶ I/O Isolation 2500 VDC
- ▶ Operating Ambient Temp. Range -40°C to +85°C
- ▶ Overload/Voltage and Short Circuit Protection
- ▶ Remote On/Off Control
- ▶ Designed-in Conducted EMI meet EN55032 Class A & FCC Level A
- ▶ Designed-in EMC Immunity meet EN61000-4-2,3,4,5,6,8
- ▶ UL/cUL/IEC/EN 60950-1 Safety Approval & CE Marking



PRODUCT OVERVIEW

The MINMAX MRWI60C series is a new range of regulated DC/DC converter modules with ultra-wide 4:1 input voltage ranges. The product comes in a fully encapsulated module with screw terminal block and is suitable for easy chassis mounting or also for DIN-rail mounting.

Featuring an extended operating temperature range from -40°C to +80°C, EMC compliance to EN 61000-6-1 standard these modules have been designed particularly for industrial applications.

Model Selection Guide

Model Number	Input Voltage (Range)	Output Voltage	Output Current	Input Current		Max. capacitive Load	Efficiency (typ.)
				Max.	@ No Load		
	VDC	VDC	mA	mA(typ.)	mA(typ.)	µF	%
MRWI60-24S051C	24 (9 ~ 36)	5.1	12000	2833	100	20400	90
MRWI60-24S12C		12	5000	2747	100	3540	91
MRWI60-24S24C		24	2500	2747	110	890	91
MRWI60-24S48C		48	1250	2747	60	220	91
MRWI60-48S051C	48 (18 ~ 75)	5.1	12000	1401	40	20400	91
MRWI60-48S12C		12	5000	1359	60	3540	92
MRWI60-48S24C		24	2500	1374	60	890	91
MRWI60-48S48C		48	1250	1374	50	220	91

Input Specifications

Parameter		Model	Min.	Typ.	Max.	Unit
Input Surge Voltage (100 ms max.)	24V Input Models		-0.7	---	50	VDC
	48V Input Models		-0.7	---	100	
Start-Up Threshold Voltage	24V Input Models		---	---	9	
	48V Input Models		---	---	18	
Under Voltage Shutdown	24V Input Models		---	7.5	---	
	48V Input Models		---	16	---	
Start Up Time	Power Up	Nominal Vin and Constant Resistive Load	---	---	50	ms
	Remote On/Off		---	---	50	ms
Input Filter		All Models	Internal Pi Type			

Remote On/Off Control					
Parameter	Conditions	Min.	Typ.	Max.	Unit
Converter On	3.5V ~ 12V or Open Circuit				
Converter Off	0V ~ 1.2V or Short Circuit				
Control Input Current (On)	Vctrl = 5.0V	---	---	0.5	mA
Control Input Current (Off)	Vctrl = 0V	---	---	-0.5	mA
Control Common	Referenced to Negative Input				
Standby Input Current	Supply Off & Nominal Vin	---	3	---	mA

Output Specifications						
Parameter	Conditions/Model	Min.	Typ.	Max.	Unit	
Output Voltage Setting Accuracy		---	±1.0	±2.0	%Vnom.	
Line Regulation	Vin=Min. to Max. @Full Load	---	±0.2	±1.5	%	
Load Regulation	Io=0% to 100%	---	±0.5	±1.0	%	
Minimum Load	No minimum Load Requirement					
Ripple & Noise	0-20MHz bandwidth	5.1V Output Models	---	---	100	mV _{P-P}
		12V & 24V Output Models	---	---	150	mV _{P-P}
		48V Output Models	---	---	200	mV _{P-P}
Transient Recovery Time	25% Load Step Change ₍₂₎	---	250	---	μsec	
Transient Response Deviation		---	±3	±5	%	
Over Voltage Protection	Zener diode clamp	---	120	---	% of Vo	
Temperature Coefficient		---	±0.02	---	%/°C	
Over Load Protection	Hiccup	---	150	---	%	
Short Circuit Protection	Hiccup Mode 0.25 Hz typ., Automatic Recovery					

General Specifications					
Parameter	Conditions	Min.	Typ.	Max.	Unit
I/O Isolation Voltage	60 Seconds	2500	---	---	VDC
I/O Isolation Resistance	500 VDC	1000	---	---	MΩ
I/O Isolation Capacitance	100KHz, 1V	---	---	3000	pF
Switching Frequency		---	210	---	KHz
MTBF (calculated)	MIL-HDBK-217F@25°C, Ground Benign	242,029			Hours
Safety Approvals	UL/cUL 60950-1 recognition (UL certificate), IEC/EN 60950-1 (CB-report)				

Environmental Specifications				
Parameter	Conditions/Model	Min.	Max.	Unit
Operating Ambient Temperature Range Natural Convection ⁽⁵⁾ Nominal Vin, 100% Load (for Power Derating see relative Derating Curves)	MRWI60-48S12C	-40	76	°C
	MRWI60-24S12C, 24S24C, 24S48C MRWI60-48S051C, 48S24C, 48S48C		74	
	MRWI60-24S051C		71	
Thermal Impedance	Natural Convection	3.5	---	°C/W
	100LFM Convection	1.95	---	°C/W
	200LFM Convection	1.61	---	°C/W
	400LFM Convection	1.33	---	°C/W
Case Temperature		---	+95	°C
Storage Temperature Range		-50	+125	°C
Humidity (non condensing)		---	95	% rel. H
Cooling	Natural Convection			

EMC Specifications

Parameter	Standards & Level		Performance
EMI	EMI Conducted Class A without adding any external components	EN55032, FCC part 15	Class A
	EMI Radiated Class A external components		
EMS	EN55024		
	ESD	EN61000-4-2 Air \pm 8kV , Contact \pm 4kV	A
	Radiated immunity	EN61000-4-3 10V/m	A
	Fast transient	EN61000-4-4 \pm 2kV	A
	Surge	EN61000-4-5 \pm 2kV	A
	Conducted immunity	EN61000-4-6 10Vrms	A
	PFMF	EN61000-4-8 30A/M	A

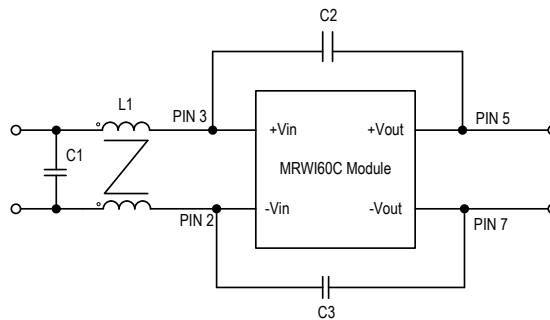
External Filter meets Radiated EMI EN55032 class A; FCC part 15 level A

Model	L1	C1	C2	C3
MRWI60-24SXXC	175 μ H/175 μ H	4.7 μ F/50V	220pF/3KV	220pF/3KV
MRWI60-48SXXC	175 μ H/175 μ H	3.3 μ F/100V	220pF/3KV	220pF/3KV

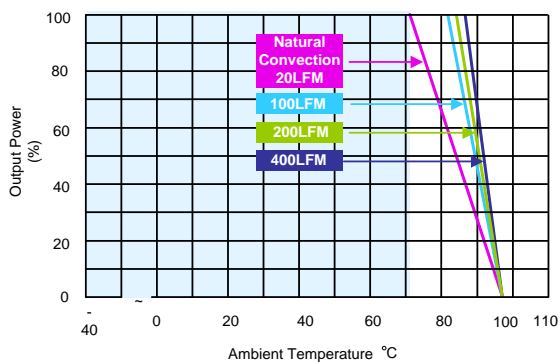
Power Derating Curve

MRWI60-24S051C

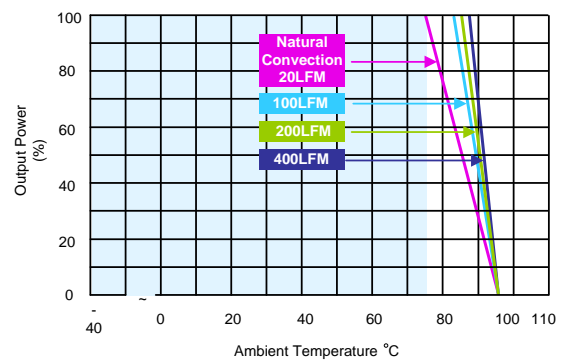

MRWI60-24S12C,24S24C,24S48C,48S051C,48S24C,48S48C

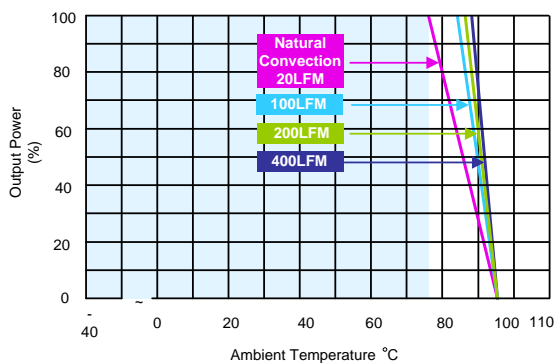

MRWI60-48S12C

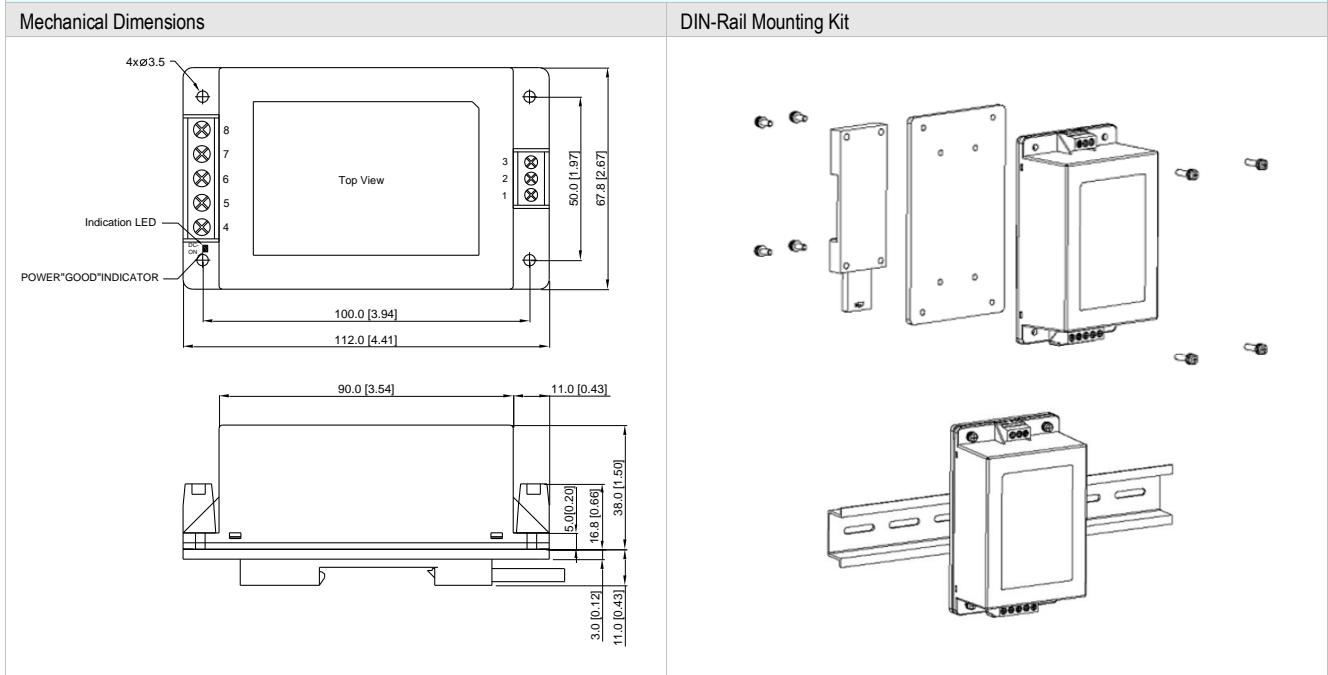
Package Specifications with DIN Rail Mounting Bracket (order code AC-DIN-02)

Physical Characteristics

Case Size	: 112.0x67.8x38.0mm (4.41x2.67x1.50 inches)
Case Material	: Plastic resin (flammability to UL 94V-0 rated)
Weight	: 353g

Order Code Table

Standard	DIN Rail	Converter with DIN Rail Mounting
MRWI60-24S051C	AC-DIN-02	MRWI60-24S051C-DIN02
MRWI60-24S12C	AC-DIN-02	MRWI60-24S12C-DIN02
MRWI60-24S24C	AC-DIN-02	MRWI60-24S24C-DIN02
MRWI60-24S48C	AC-DIN-02	MRWI60-24S48C-DIN02
MRWI60-48S051C	AC-DIN-02	MRWI60-48S051C-DIN02
MRWI60-48S12C	AC-DIN-02	MRWI60-48S12C-DIN02
MRWI60-48S24C	AC-DIN-02	MRWI60-48S24C-DIN02
MRWI60-48S48C	AC-DIN-02	MRWI60-48S48C-DIN02

Test Setup

Peak-to-Peak Output Noise Measurement Test

Scope measurement should be made by using a BNC socket, measurement bandwidth is 0-20 MHz. Position the load between 50 mm and 75 mm from the DC/DC Converter.

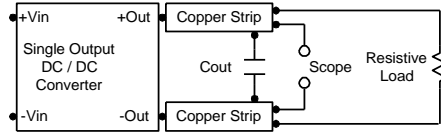

Technical Notes

Remote On/Off

Positive logic remote on/off turns the module on during a logic high voltage on the remote on/off pin, and off during a logic low. To turn the power module on and off, the user must supply a switch to control the voltage between the on/off terminal and the -Vin terminal. The switch can be an open collector or equivalent. A logic low is 0V to 1.2V. A logic high is 3.5V to 12V. The maximum sink current at the on/off terminal (Pin 1) during a logic low is -100 μ A.

Overload Protection

To provide hiccup mode protection in a fault (output overload) condition, the unit is equipped with internal current limiting circuitry and can endure overload for an unlimited duration.

Overvoltage Protection

The output overvoltage clamp consists of control circuitry, which is independent of the primary regulation loop, that monitors the voltage on the output terminals. The control loop of the clamp has a higher voltage set point than the primary loop. This provides a redundant voltage control that reduces the risk of output overvoltage. The OVP level can be found in the output data.

Input Source Impedance

The power module should be connected to a low ac-impedance input source. Highly inductive source impedances can affect the stability of the power module. In applications where power is supplied over long lines and output loading is high, it may be necessary to use a capacitor at the input to ensure startup. Capacitor mounted close to the power module helps ensure stability of the unit, it is recommended to use a good quality low Equivalent Series Resistance (ESR < 1.0 Ω at 100 KHz) capacitor of a 10 μ F for the 24V and 48V devices.

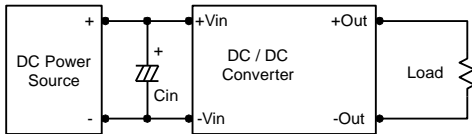

Output Ripple Reduction

A good quality low ESR capacitor placed as close as practicable across the load will give the best ripple and noise performance. To reduce output ripple, it is recommended to use 4.7 μ F capacitors at the output.

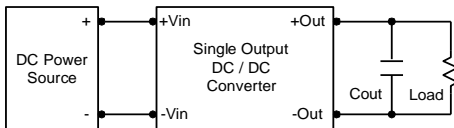

Maximum Capacitive Load

The MRWI60C series has limitation of maximum connected capacitance at the output. The power module may be operated in current limiting mode during start-up, affecting the ramp-up and the startup time. The maximum capacitance can be found in the data sheet.

Thermal Considerations

Many conditions affect the thermal performance of the power module, such as orientation, airflow over the module and board spacing. To avoid exceeding the maximum temperature rating of the components inside the power module, the case temperature must be kept below 95°C. The derating curves are determined from measurements obtained in a test setup.

