

## FEATURES

- ▶ Industrial SMD Package
- ▶ Fully Regulated Output Voltage
- ▶ Low Ripple & Noise
- ▶ Excellent Efficiency up to 97%
- ▶ Operating Ambient Temp. Range -40°C to +90°C
- ▶ No Min. Load Requirement
- ▶ Over Temp. and Short Circuit Protection
- ▶ Remote ON/OFF Control, Output Voltage Trim
- ▶ Qualified for Lead-free Reflow Solder Process  
According to IPC/JEDEC J-STD-020D.1
- ▶ Tape & Reel Package Available



## PRODUCT OVERVIEW

The MINMAX M78SAR-0.5 series is a new range of switching regulators designed as a drop-in replacement for old LM78xx linear regulators with low efficiency. The very high efficiency of these step-down converters allow an operating temperature up to 80°C at full-load without need of any heatsink. The high efficiency and low stand-by power consumption of these switching regulators offer the designer a new, cost-efficient solution for many applications.

### Model Selection Guide

Model Number	Input Voltage Range <sup>(6)</sup> VDC	Output Voltage		Output Current	Max. capacitive Load μF	Efficiency (typ.)	Efficiency (typ.)
		Normal	Adjust Range <sup>(8)</sup>	Max.		@Min. Vin	@Max. Vin
		VDC	VDC	mA		%	%
M78SAR015-0.5	4.75 ~ 32	1.5	1.4~2.5	500	220	73	63
M78SAR018-0.5		1.8	1.5~3	500	220	82	71
M78SAR025-0.5		2.5	1.5~3	500	220	87	77
M78SAR033-0.5		3.3	3~5.5	500	220	91	81
M78SAR05-0.5	6.5 ~ 32	5	3~8	500	220	94	86
M78SAR065-0.5	8 ~ 32	6.5	3.3~11	500	220	95	88
M78SAR09-0.5	11 ~ 32	9	4.5~12.6	500	220	96	92
M78SAR12-0.5	15 ~ 32	12	4.5~13.5	500	220	97	94
M78SAR15-0.5	18 ~ 32	15	4.5~15.5	500	220	97	95

### Input Specifications

Parameter	Conditions	Min.	Typ.	Max.	Unit
Input Surge Voltage (1 sec. max.)		-0.3	---	34	VDC
Internal Filter Type		Capacitor			
Input Filter	All Models	Internal Capacitor			
Short Circuit Input Power		---	---	1.5	W
Input Current	@No Load	---	5	---	mA

### Remote On/Off Control

Parameter	Conditions	Min.	Typ.	Max.	Unit
Converter On	Open or 2.4V < Vr < 5V				
Converter Off	GND or 0 < Vr < 1.6V				
Standby Input Current	Supply Off & 24 Vin	---	---	35	μA

Output Specifications						
Parameter	Conditions		Min.	Typ.	Max.	Unit
Output Voltage Setting Accuracy			---	±2.0	±3.0	%Vnom.
Line Regulation	Vin=Min. to Max. @Full Load	1.5V to 6.5V	---	±0.2	±0.4	%
		9V to 15V	---	±0.1	±0.2	%
Load Regulation	Io=10% to 100%	1.5V to 6.5V	---	±0.4	±0.6	%
		9V to 15V	---	±0.25	±0.4	%
Minimum Load	No minimum Load Requirement					
Ripple & Noise	0-20MHz Bandwidth	1.5V to 6.5V	---	---	30	mV <sub>P-P</sub>
		9V to 15V	---	---	40	mV <sub>P-P</sub>
Transient Recovery Time	50% Load Step Change		---	100	---	μsec
Transient Response Deviation			---	±2	---	%
Temperature Coefficient			---	---	±0.015	%/°C
Short Circuit Protection	Continuous, Automatic Recovery					

General Specifications						
Parameter	Conditions		Min.	Typ.	Max.	Unit
I/O Isolation Voltage			none			
Switching Frequency			280	330	380	KHz
MTBF(calculated)	MIL-HDBK-217F@25°C, Ground Benign		2,000,000			Hours
Moisture Sensitivity Level (MSL)	IPC/JEDEC J-STD-020D.1		Level 2			

Environmental Specifications						
Parameter	Conditions		Min.	Typ.	Max.	Unit
Operating Ambient Temperature Range (See Power Derating Curve)	Natural Convection		-40	---	+90	°C
Case Temperature			---	---	+100	°C
Storage Temperature			-55	---	+125	°C
Thermal Shutdown	Internal IC junction		---	160	---	°C
Humidity (non condensing)			---	---	95	% rel. H
Cooling	Natural Convection					
Lead-free reflow solder process	IPC/JEDEC J-STD-020D.1					

EMC Specifications			
Parameter	Standards & Level		Performance
EMI	Radiation without adding any external components		Class B
	Conduction with external components		
EMS	ESD	EN61000-4-2 Air±8kV	A
	Radiated immunity	EN61000-4-3 3V/m	A
	Fast transient <sub>(4)</sub>	EN61000-4-4 ±0.5kV	A
	Conducted immunity	EN61000-4-6 3Vrms	A
	PFMF	EN61000-4-8 3A/m	A

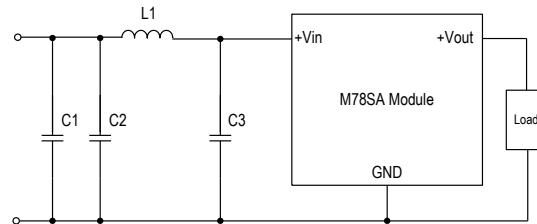
**EMI Filter meets Conducted EMI EN55022 class B; FCC part 15 level A**

Class	C1	C2	C3	L1
Class A	---	4.7 $\mu$ F/50V 1206 MLCC	4.7 $\mu$ F/50V 1206 MLCC	Würth Elektronik NO. 744774033
Class B	4.7 $\mu$ F/50V 1206 MLCC	4.7 $\mu$ F/50V 1206 MLCC	4.7 $\mu$ F/50V 1206 MLCC	Würth Elektronik NO. 74477410

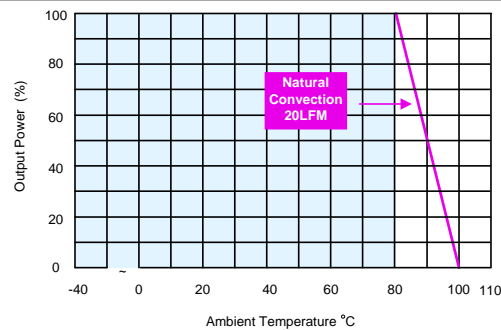
**Power Derating Curve**

**Notes**

- 1 Specifications typical at Ta=+25°C, resistive load, nominal input voltage, rated output current unless otherwise noted.
- 2 Other input and output voltage may be available, please contact factory.
- 3 We recommend to protect the converter by a slow blow fuse in the input supply line.
- 4 The M78SAR-0.5 series can meet EN61000-4-4 by adding a capacitor across the input pins. Suggested capacitor CHEMI-CON KY 330 $\mu$ F/100V.
- 5 That "natural convection" is about 20LFM but is not equal to still air (0 LFM).
- 6 With a input capacitor 22 $\mu$ F/50V for input voltage >28VDC, the input voltage allows 32VDC, max.
- 7 Specifications are subject to change without notice.

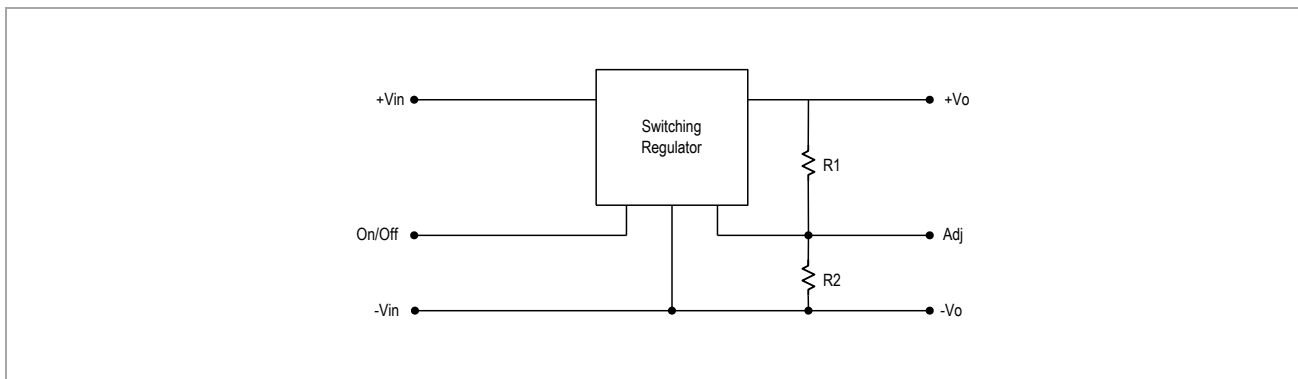
Adjustment Resistor Values																		
	M78SAR015-0.5		M78SAR018-0.5		M78SAR025-0.5		M78SAR033-0.5		M78SAR05-0.5		M78SAR065-0.5		M78SAR09-0.5		M78SAR12-0.5		M78SAR15-0.5	
Vout(nom.)	1.5VDC		1.8VDC		2.5VDC		3.3VDC		5.0VDC		6.5VDC		9.0VDC		12VDC		15VDC	
Vout(adj)	R1	R2	R1	R2	R1	R2	R1	R2	R1	R2	R1	R2	R1	R2	R1	R2	R1	R2
1.4 (V)	1 K $\Omega$																	
1.5 (V)			3K $\Omega$		200 $\Omega$													
1.8 (V)		6.49 K $\Omega$			12K $\Omega$													
2.5 (V)		0.47 K $\Omega$		11.8K $\Omega$														
3.0 (V)				4.64K $\Omega$		44.2K $\Omega$	88.4K $\Omega$		17K $\Omega$									
3.3 (V)									27K $\Omega$		15K $\Omega$							
3.6 (V)								60.4K $\Omega$	42K $\Omega$		21.5K $\Omega$							
3.9 (V)								28K $\Omega$	58K $\Omega$		30.1K $\Omega$							
4.5 (V)								11.3K $\Omega$	180K $\Omega$		56.3K $\Omega$		26K $\Omega$		17K $\Omega$		10.5 K $\Omega$	
4.9 (V)								7.15K $\Omega$	850K $\Omega$		78.7K $\Omega$		36K $\Omega$		24K $\Omega$		15.8 K $\Omega$	
5.0 (V)								6.34K $\Omega$			86K $\Omega$		39K $\Omega$		26K $\Omega$		17.4 K $\Omega$	
5.1 (V)								5.9K $\Omega$		231K $\Omega$	97K $\Omega$		42K $\Omega$		28K $\Omega$		18.7 K $\Omega$	
5.5 (V)								3.9K $\Omega$		56.2K $\Omega$	154K $\Omega$		56K $\Omega$		36K $\Omega$		24.9 K $\Omega$	
6.5 (V)										14K $\Omega$			112K $\Omega$		63K $\Omega$		42.2 K $\Omega$	
8.0 (V)										2.32K $\Omega$		22.6K $\Omega$	400K $\Omega$		125K $\Omega$		78.7 K $\Omega$	
9.0 (V)												9.53K $\Omega$			200K $\Omega$		113 K $\Omega$	
10 (V)												3.92K $\Omega$					160 K $\Omega$	
11 (V)												825 $\Omega$		54.9K $\Omega$	345K $\Omega$		232 K $\Omega$	
12 (V)														3.6K $\Omega$			340 K $\Omega$	
12.6 (V)														0 $\Omega$		180K $\Omega$	464 K $\Omega$	
13.5 (V)																57.6 K $\Omega$	787 K $\Omega$	
15.5 (V)																		300 K $\Omega$

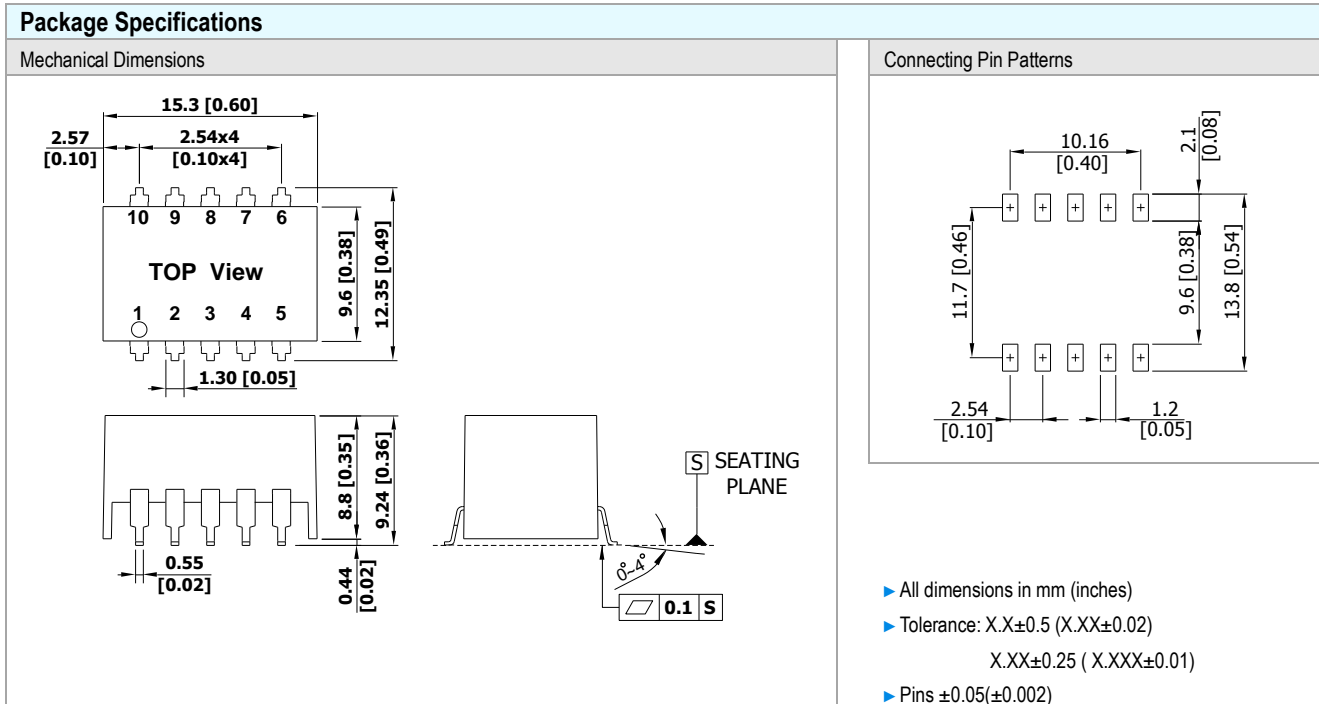



Pin Connections	
Pin	Function
1	+Vin
2	+Vin
3	GND
4	+Vout
5	+Vout
6	Vadj.
7	GND
8	GND
9	GND
10	Remote On/Off

Physical Characteristics	
Case Size	: 15.3x9.6x8.8mm (0.60x0.38x0.35 inches)
Case Material	: Non-Conductive Black Plastic (flammability to UL 94V-0 rated)
Pin Material	: Phosphor bronze
Weight	: 1.7g

### Test Setup

#### Peak-to-Peak Output Noise Measurement Test

Use a Cout 0.47 $\mu$ F ceramic capacitor. Scope measurement should be made by using a BNC socket, measurement bandwidth is 0-20 MHz. Position the load between 50 mm and 75 mm from the DC/DC Converter.

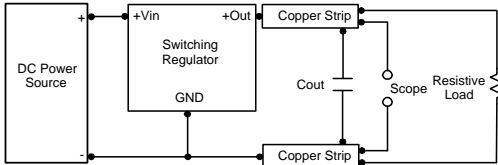

### Technical Notes

#### Output Ripple Reduction

A good quality low ESR capacitor placed as close as practicable across the load will give the best ripple and noise performance. To reduce output ripple, it is recommended to use 3.3 $\mu$ F capacitors at the output.

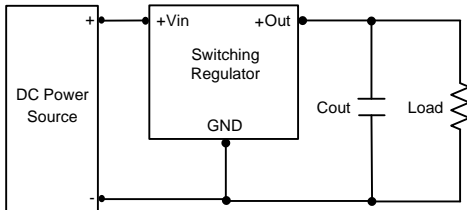

#### Maximum Capacitive Load

The M78SAR-0.5 series has limitation of maximum connected capacitance on the output. The power module may operate in current limiting mode during start-up, affecting the ramp-up and the startup time. The maximum capacitance can be found in the data sheet.